



Monitran Ltd. Monitor House, Hazlemere Road  
Penn, Bucks. HP10 8AD England  
Tel: +44 (0) 1494 816569  
Fax: +44 (0) 1494 812256  
E-Mail: [info@monitran.co.uk](mailto:info@monitran.co.uk)  
Web Site: [www.monitran.co.uk](http://www.monitran.co.uk)

**MTN/ECPD + MTN/EP SERIES**

**EDDY CURRENT PROBE SYSTEMS**

**OPERATING HANDBOOK**

## **General Description**

The MTN/ECPD Driver Unit + MTN/EP Series Eddy Current Probes are non-contact measurement systems designed to monitor the gap between the probe tip and a metal target. Typically, the probes are used in machinery systems to monitor the end thrust or radial vibration of a rotating shaft. Probes are available with linear ranges of 2mm, 5mm, 8.5mm and 12mm as shown in figure 1. The diameter of the shaft to be monitored and the expected movement will determine the range of the probe required.

The system is calibrated at the factory, using a low carbon steel grade SAE 4140 target, to give a linear (volts per millimetre) output. The probes should give acceptable results for other grades of low carbon steel, but stainless steel or non-ferrous targets will require special calibration at the factory. Curved surfaces will also affect the calibration, and shaft diameters should be greater than 20 times the probe range to maintain linearity.

All systems are supplied with a calibration certificate stating sensitivity in volts/mm.

## **Probe Description**

The probe unit consists of a thermally stable plastic tip, a stainless steel threaded body, and an integral coaxial cable and connector. In standard probes the coaxial cable is protected by a stainless steel overbraid. Dimensions for the standard range of probes are shown in Figure 1. The probe tip contains an encapsulated coil assembly which, when connected to the driver unit, produces a high frequency oscillation that induces eddy currents in the target material. The eddy currents induced in the target, and hence the oscillation amplitude, are proportional to the probe gap.

Probe extension cables are available and must be specified at time of order. No other probe extensions are permissible since calibration is seriously affected by cable capacitance. The maximum length of the probe and extension cable is 9 metres. The probe connects to the driver unit via a miniature SMC coaxial connector, the body of which is connected to the power supply/signal 0V terminal. The stainless steel overbraid is not connected.

## **Driver Description**

The driver unit contains the high frequency oscillator that drives the probe. Rectifying and linearising circuits convert the oscillator voltage from the probe into a dc voltage proportional to gap. The driver unit is powered by -24Vdc supply, via screw terminal connections. The output voltage, proportional to the probe gap, is a negative dc voltage measured with reference to the common 0V terminal. The MTN/ECPD+24V version operates from a +24V supply and gives positive output with respect to the power supply 0V, hence polarities in Fig.4 should be reversed. The output dc voltage can be used for setting the probe to the correct distance from the target. When the target is in motion, the ac waveform superimposed on the dc gap voltage indicates the vibration amplitude. A calibration potentiometer is fitted on the driver unit to enable very small adjustments to the probe sensitivity, if necessary.

The driver unit is housed in a robust metal enclosure and can be mounted at any convenient location on or around the machine. Driver dimensions are shown in Figure 3.

## Probe Installation

The MTN/EP series probes and drivers are calibrated together at the factory using a flat SAE4140 grade carbon steel target. The use of other target materials or small diameter curved targets will invalidate the factory calibration. If probe extension cables are supplied, they must be used in order to maintain the calibration accuracy.

The probe position should be chosen to minimise the effect of surface roughness, changes in diameter or eccentricity, which will affect the accuracy of the measurement. The target area, perpendicular to the probe tip, must have a diameter of at least 3 x the probe diameter with no discontinuities, such as spigots or keyways, impinging. In addition, no other metal parts should invade the area as shown in Figure 2. When in position, probes are secured by the lock nuts provided.

Cable cleats can be used to fix the probe coaxial cable to machine surfaces for neatness, however to avoid possible ground loop problems, the SMC connectors should be isolated from the machine frame using sleeve or insulating tape. The stainless steel overbraid is not connected to the coaxial connector and can be fixed directly to the machine.

## Driver Unit Installation

The driver unit can be mounted directly to the machine frame, or in a protective enclosure easily accessible to allow for setting-up. It should be sited away from sources of electrical interference such as large motors or inverters. Fixing details are shown in Figure 3.

Any number of drivers may be fitted in an enclosure but note that ***it is essential that the serial numbers on the probe and the driver unit match***. Care must be taken not to over-tighten the probe connector, which should be tightened to a torque of approximately 0.6Nm (5 lb-in).

Figure 4 shows the connections from the driver unit to the power supply and measuring instrument. It should be noted that 0V/Common terminal is internally connected to the driver unit case. Suitable grounding arrangements should be made to avoid ground loops and mains pick-up. The optimum grounding scheme will depend on whether or not the driver case is fixed to grounded metal and on the electro-magnetic environment.

## System Set-Up

For both the axial thrust and the radial vibration applications, it is recommended that the probe gap is set to mid-range eg 1mm for the MTN/EP080, since this is where best linearity is achieved. Other gap settings can be used if necessary, but care must be taken to avoid the possibility of the probe coming into contact with the target under fault conditions. The gap can be set using either feeler gauges or, if access is not possible, by monitoring the dc output voltage of the driver. For gap adjustment, flats are provided on the rear end of the probe to enable it to be screwed in or out following release of the locknuts.

Gap is calculated from the simple relationship  $\text{mm} = V_{dc}/\text{probe sensitivity}$ .

For sinusoidal vibrations the peak to peak displacement can be calculated from the output voltage measured using a true RMS indicating meter as follows:-  $\text{mm p-p} = 2.83V_{rms}/\text{probe sensitivity}$ .

If the target material is incompatible with the factory calibration and large calibration errors occur, it may be possible to re-calibrate the probe/driver combination using the procedure in Appendix 1.

**Figure 1. Probe Dimensions**

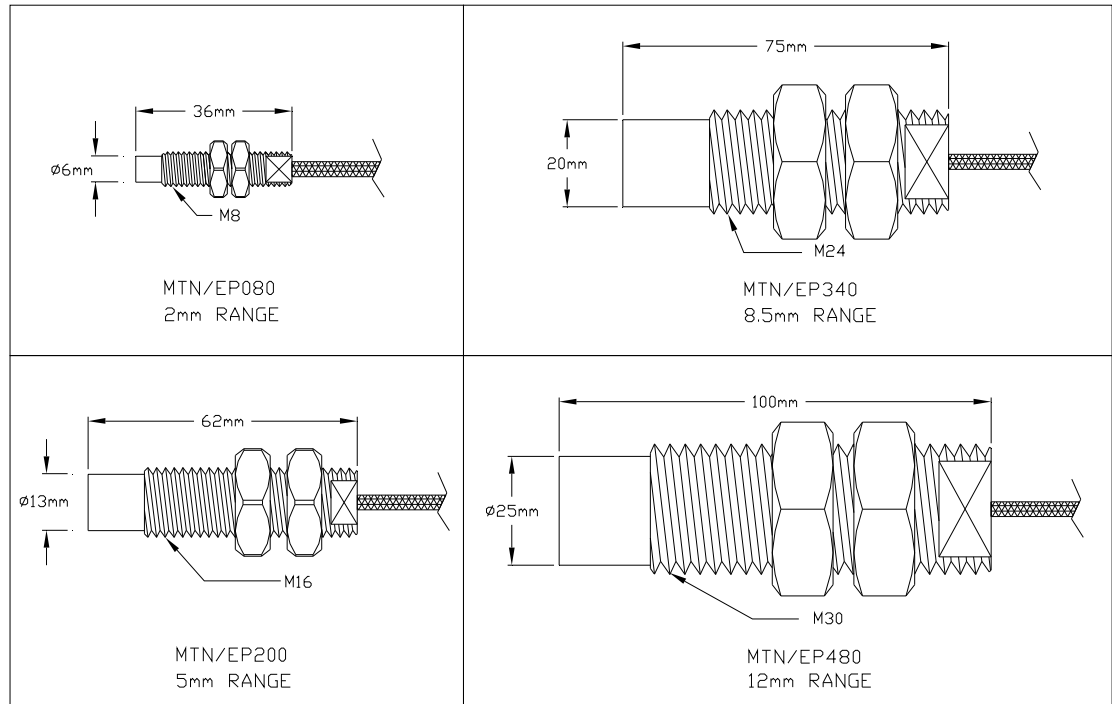

**Figure 2. Recommended Minimum Clearance for Probe Tip**

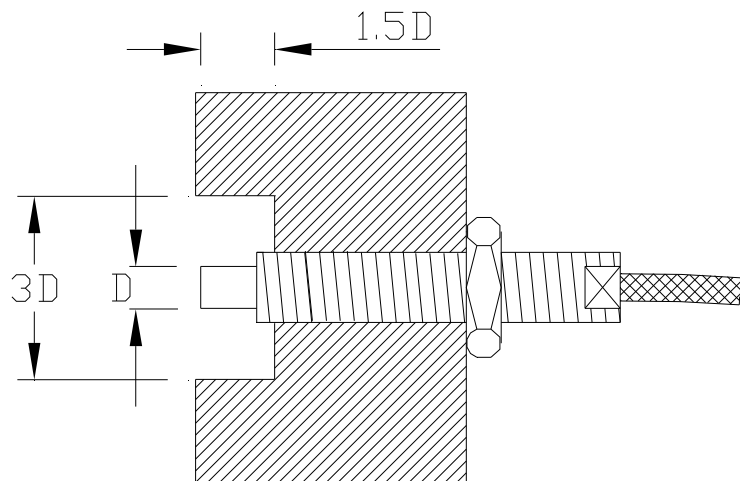

**Figure 3. Driver Unit Dimensions**

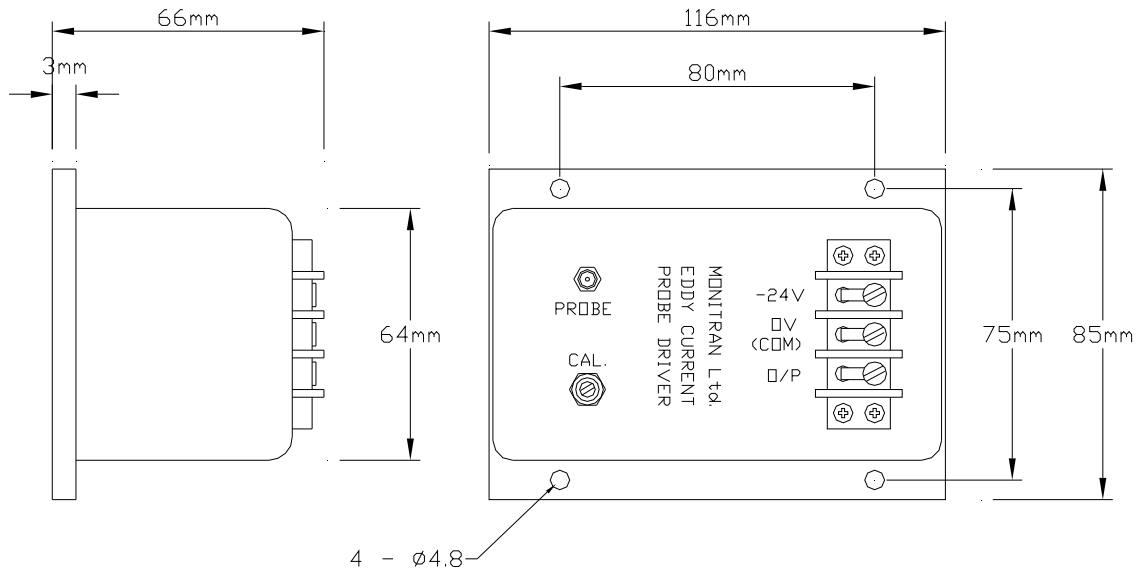

**Figure 4. System Connections**

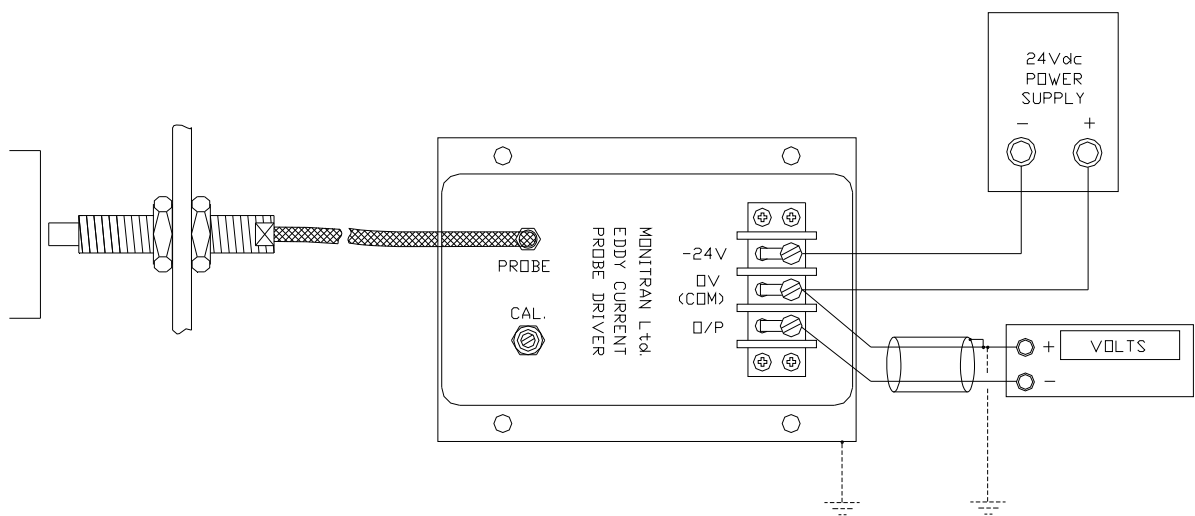

## MTN/ECPD + MTN/EP Series Eddy Current Probe Technical Specification

Linear Range	MTN/EP080 - 0.1mm to 2mm MTN/EP200 - 0.25mm to 5mm MTN/EP340 - 0.4mm to 8.5mm MTN/EP480 - 0.6mm to 12mm
Voltage Output Sensitivity	MTN/EP080 - 8 Volts/mm MTN/EP200 - 3.6Volts/mm MTN/EP340 - 2Volts/mm MTN/EP480 - 1.5Volts/mm
Output Impedance	<50 $\Omega$
Power Supply	-24Vdc $\pm$ 2V @ 35mA (+24V for MTN/ECPD+24V) Maximum Ripple 1%
Linearity	$\pm$ 1% of full range
Frequency Range	AC Vibration 5 Hz – 1 kHz
Operating Temperature	Probe -20°C to +180°C Driver -20°C to +80°C
Temperature Sensitivity	<5% at 150°C
Connectors	Probe – SMC miniature coaxial connector Power In /Output – M4 Screw Terminals
Weight (Driver only)	450g

## Appendix 1

### Probe Calibration

The 'Cal' potentiometer fitted on the driver unit enables fine adjustment of the driver output to compensate for minor differences in target materials. It should be used with great care, however, since large linearity errors can occur. The 'Cal' potentiometer should be used when the output voltage is no more than  $\pm 1\%$  of the expected value with the gap at exactly the mid range. The driver output voltage can be trimmed exactly without seriously affecting the probe linearity. If the error in the output voltage is greater than  $\pm 1\%$  and is unacceptable, it will be necessary to re-calibrate the probe and driver combination by re-setting the internal zero, gain and linearity potentiometers shown in Fig.4. This is an iterative procedure requiring suitable slip gauges to set the probe gap, a voltmeter to measure the driver output voltage, and a potentiometer trimmer. The procedure can be accomplished more conveniently using an MTN/ECPD Test Jig with the appropriate target material machined to fit the jig. The procedure is as follows:-

- 1) Remove the four screws retaining the driver base-plate and gain access to the encapsulated circuit board as shown in Figure 4.
- 2) Set the probe gap to 10% of range and adjust the zero potentiometer P3 to give the appropriate output on the voltmeter. eg. 1.60V for an MTN/EP080
- 3) Set the probe/target gap to 50% of probe range and adjust the gain potentiometer P1 for 50% output. eg. 8.00V for an MTN/EP080
- 4) Set the probe/target gap to the probe maximum and adjust the linearity potentiometer P2 for 100% output. eg.16.00V for an MTN/EP080

All potentiometer adjustments are interactive and it will be necessary to cycle backwards and forwards through steps 1 to 4 several times to attain a correct calibration.

**Figure 4. Internal Calibration Potentiometers**

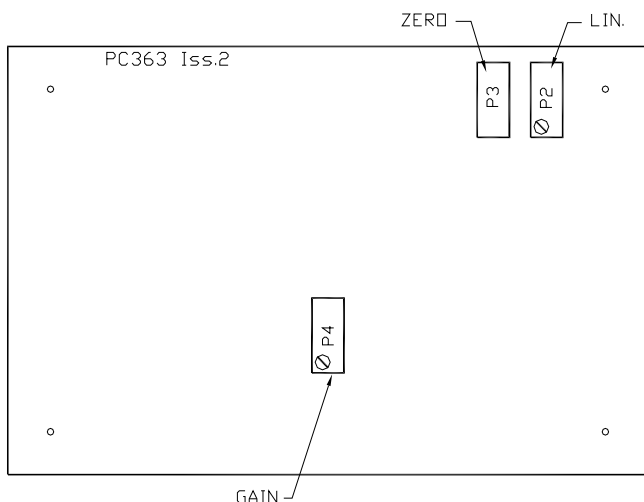

## **WARRANTY**

The product is guaranteed against defects in materials and workmanship, subject to specific exclusions, for the period of 12 months from date of purchase.

This warranty is void if a repair is attempted by unauthorised persons or agents, or, if the product has been used for purposes for which it was not intended, and or subjected to abuse or wilful neglect.

Additional exclusions are incandescent lamps, fuses, batteries or any consumable items or components supplied.

No liability can be accepted for loss of items and or component parts, it is expected that the user take sufficient precautions to safeguard all guaranteed items.